

Performance and Quality Issues for 802.11 Embedded Wireless Modules

There are a number of 802.11 wireless modules on the market today. But all embedded wireless modules are not created equal, especially if you are an OEM manufacturer. This white paper discusses some of the issues that you need to consider when selecting an embedded wireless module for use in your product. It also includes a real-life case study of an OEM embedded wireless module application.

White paper by Silex Technology America, Inc.

August 1, 2007

Copyright © 2007 Silex Technology America, Inc.

REV. 1

The Embedded Wireless Module Market

Because of the popularity of 802.11 wireless networks, a number of manufacturers are now producing embedded wireless modules that enable 802.11 connectivity for devices. These modules generally use a standard form factor such as Mini PCI, Compact Flash, or SDIO. So given the large number of choices, how should an OEM manufacturer go about selecting an embedded wireless module?

There are several factors to consider in making a decision, including:

- *Product Quality.* Does the embedded wireless module manufacturer have the proper procedures in place to ensure a high quality product, and does this manufacturer have the necessary experience and competencies?
- *Design Quality.* Is the product designed to provide the maximum performance and stability?
- *Supply Quality.* Can the embedded wireless module manufacturer meet your supply requirements?
- *Support.* Will the embedded wireless module manufacturer provide you with the support you will need throughout your product's life cycle?
- *Price.* The embedded wireless module must be competitively priced.

Overall product quality is difficult to guarantee unless a wireless embedded module manufacturer controls all of these key areas. Silex has proven competencies in all of these areas, which enables us to provide the highest quality products.

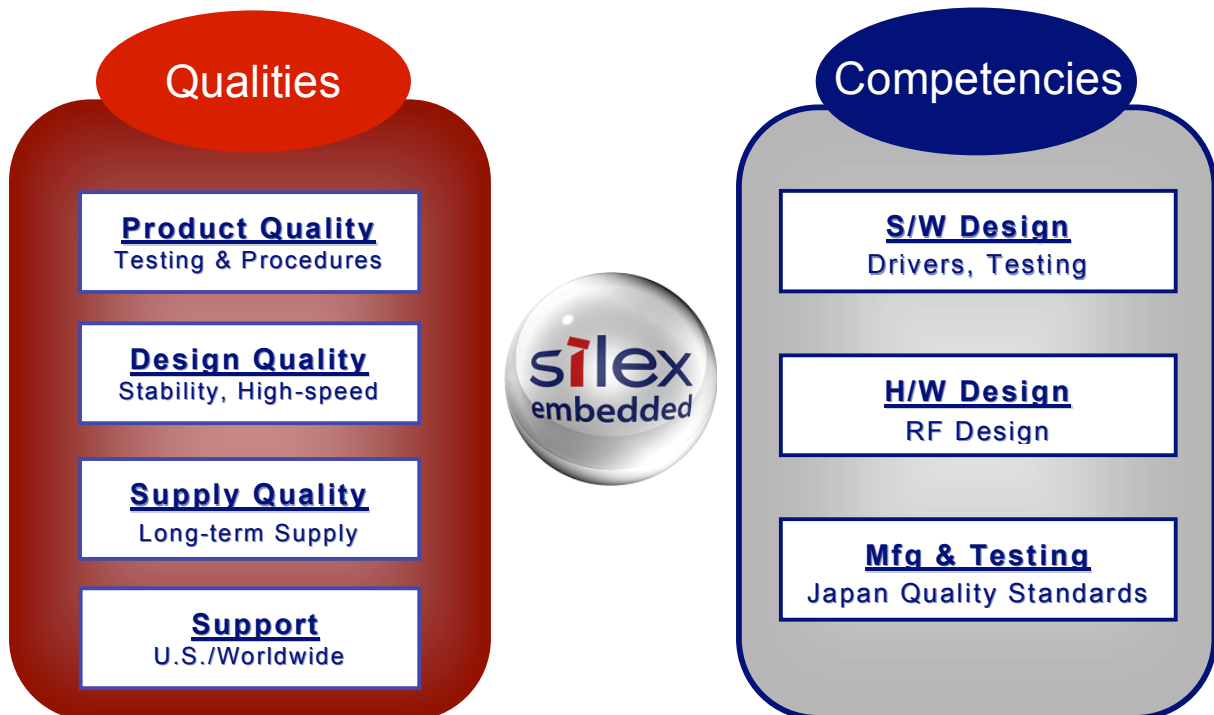

Product Quality

As an OEM manufacturer, you are no doubt concerned about reliability. Clearly you want to minimize the number of returns from customers and the associated costs with such returns. You also want to make sure that your manufacturing process is not interrupted due to unanticipated changes in the embedded wireless module (for example, quality inconsistencies due to an unannounced parts change or even the use of gray market parts). Indeed, the frequent product changes made by some embedded wireless module manufacturers can result in additional costs that easily negate any pricing advantages of their modules.

The first quality issue to consider is whether or not the embedded wireless module manufacturer has ISO 9001:2000 certification. This certification shows that the manufacturer has been independently audited and certified to be in conformance with ISO 9001:2000, which is the internationally recognized standard for quality management systems. ISO 9001:2000 certification assures that the proper and consistent procedures are being used to ensure quality output.

But ISO 9001:2000 certification by itself does not guarantee highest quality products. The embedded wireless module manufacturer must also maintain a strong corporate commitment to quality, and must implement internal quality procedures over and above the basic ISO 9001:2000 procedures. For example, Japanese manufacturers in general (Toyota and Honda are obvious examples) are renowned for their superior quality, even when compared with competitors that have ISO 9001 certification. As a Japanese manufacturer, Silex has a similar commitment to quality with the following advantages:

- Silex controls the entire design, development, and manufacturing process to ensure the highest quality products.
- Every single embedded wireless module is evaluated during the manufacturing process before shipment to customers.
- There are never irregular or unnecessary changes to components on the wireless embedded modules.

One of the most important aspects of quality manufacturing is the testing process. Silex excels in this area with a unique internally developed test process. This process is used for product testing and calibration, and is based on the ART (Atheros Radio Test) source. Key testing/calibration items include:

:

- Power Calibration
- Target Power Set/Measured Test
- Spectral Mask Test
- Data Integrity Test
- Throughput Test
- PER (Packet Error Rate) Test
- SEN (Receive Sensitive) Test

By using this process to test every wireless embedded module, Silex can provide the highest quality products.

Design Quality (Performance)

Although you might think that 802.11 performance is the same for all wireless embedded modules, it turns out that this is not the case. There is a definite expertise required for designing wireless devices, so even products based on the same standard reference design using the same chip set can have different performance characteristics. For example, Silex investigated the performance of its SX-10WG module compared to several competitors with two tests:

- Field test: measured transmission speeds outdoors clear of obstacles
- Modulation accuracy test: measured how much a demodulated signal differs from an ideal signal.

The results of these tests are shown below.

Product Type	Vendor	Country	MAC/BBP Chip Set	Std.
SX-10WG	Silex	Japan	AR2413A(Atheros)	802.11b/g
AR2413A-001 Reference*	Atheros		AR2413A(Atheros)	802.11b/g
GN-WIAG02	GIGABYTE	Taiwan	AR2414A(Atheros)	802.11b/g
WLL3090-D20	ASKEY	Taiwan	AR2413A(Atheros)	802.11b/g
WL-850F	Gemtek	Taiwan	ISL 38801K(Intersil)	802.11b/g
WLI-MPCI-G54	BUFFALO	Japan	BCM94306(Broadcom)	802.11b/g
BCM94306MPSG Rev.4	Broadcom	Taiwan	BCM94306(Broadcom)	802.11b/g

*For test comparison purposes only; this is not a competing product

Table 1

Tested Embedded Wireless Modules

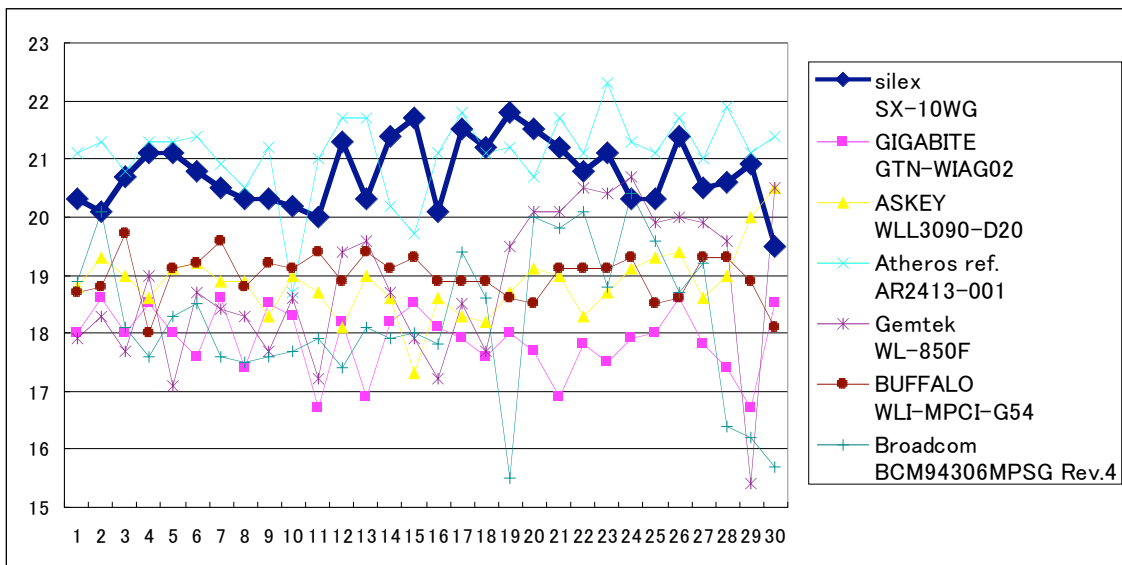

Throughput measured every minute

Chart 1

Field Test Results -- IEEE 802.11g Transmission Speed Measured at 10m Distance

Chart 1 shows that the Silex SX-10WG is faster and more stable than the competitors at relatively close distances. It is the only module that delivers performance equivalent to the Atheros reference.

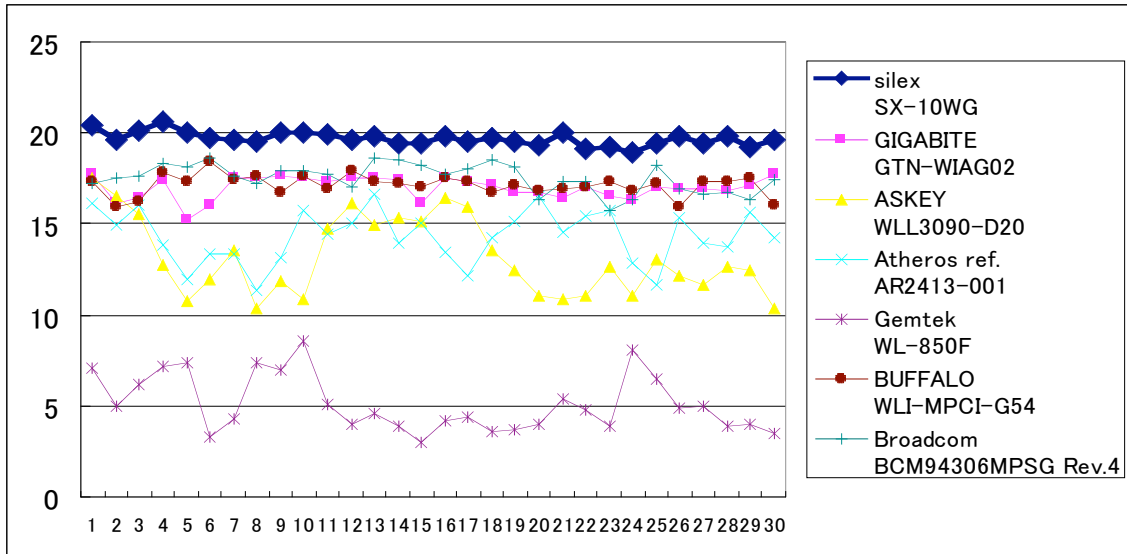

Throughput measured every minute

Chart 2

Field Test Results -- IEEE 802.11g Transmission Speed Measured at 50m Distance

Chart 2 shows that the SX-10WG is faster and more stable than the competitors at large distances. Note that the speed is not much different at 10 m or 50 m. Even though several of the competitors use the same Atheros radio as the SX-10WG, Silex's superior design capabilities result in a higher performance product.

Supply Quality and Pricing

You also need to make sure that you can meet the demand for your product at a competitive price. This means that the supplier of your embedded wireless module must have adequate capacity to produce the quantities of product that you need in a timely manner with good pricing. Silex' maintains state-of-the-art manufacturing facilities in Japan that are well-suited to handle high volume applications.

But in fact, there are a number of high-volume manufacturers of embedded wireless modules. However, some of these manufacturers do not accept small-lot orders. So if you're not buying at least 100,000 units per year, you may not even get the attention of such manufacturers.

Silex, on the other hand, has set up its manufacturing to be able to handle both large and small lot delivery needs with very competitive pricing. So no matter what quantities you require, Silex can provide you with products.

Support (OEM Focus)

By far the biggest markets for embedded wireless modules is for mass market devices like laptop computers, PDAs, and high-end mobile phones. As a result, most wireless module manufacturers focus on these markets. But if you are not a manufacturer of one of these types of devices, then these manufacturers may be unable or unwilling to provide you with the support you need.

Some of the support issues you need to consider include:

- *Compliance with major international regulatory standards.* The module should meet FCC, ETSI, VCCI, RoHS, and other standards, and the embedded wireless module manufacturer should be able to assist you in making your device compliant with the relevant standards.
- *FCC Limited Module Certification.* This certification basically allows you to declare that your device is compliant with the FCC Part 15 intentional radiation standards, thereby saving you time and money in the approval process.
- *Antenna.* Since most mass market devices have built-in antennas, most embedded wireless modules do not include an antenna and cable. Many OEM devices, on the other hand, do not have a built-in antenna, so you must purchase an antenna and cable as an extra cost item. Note that the Silex SX-10WG/WAG modules include an antenna and cable at no additional charge.
- *Engineering Support.* Integrating an embedded wireless module into your device is not a trivial process, so the wireless embedded module manufacturer should provide the technical resources required to help you successfully bring your product to market.
- *On-going Manufacturing Support.* The embedded wireless module manufacturer should also be able to provide you with the support necessary for the entire lifecycle of your product (for example, ECO notification, product end-of-life issues, etc.).

Silex has over 30 years of experience in working with OEM manufacturers, and we also use our SX-10WG/WAG wireless embedded modules in our own products. As a result, we have substantial wireless design and manufacturing expertise, and we know exactly what it takes to support our OEM customers in their development process.

Case Study – Hitachi Information & Communication Engineering, Ltd.

Hitachi Information & Communication Engineering originally used a competitor's Atheros-based Mini PCI 802.11b/g wireless module with the Hitachi WLS2-4R wireless LAN development platform. However, because Hitachi could not order the wireless module in relatively small quantities, they were forced to consider other alternatives. Hitachi chose the Silex SX-10WG as the replacement product for the following reasons:

1. The SX-10WG can be ordered in small lots at a very competitive price.
2. The module is manufactured at Silex's facilities in Japan, ensuring consistent quality and reliability plus local support (Silex local support is also available in the United States, Europe, and China).
3. The SX-10WG is compatible with the driver used by the competitor's module, since both modules use an Atheros core.

Hitachi Information & Communication Engineering is a typical SX-10WG/WAG customer because they required a high quality product designed specifically for OEM device applications (not laptops) with local support and the ability to order modules in small lots.

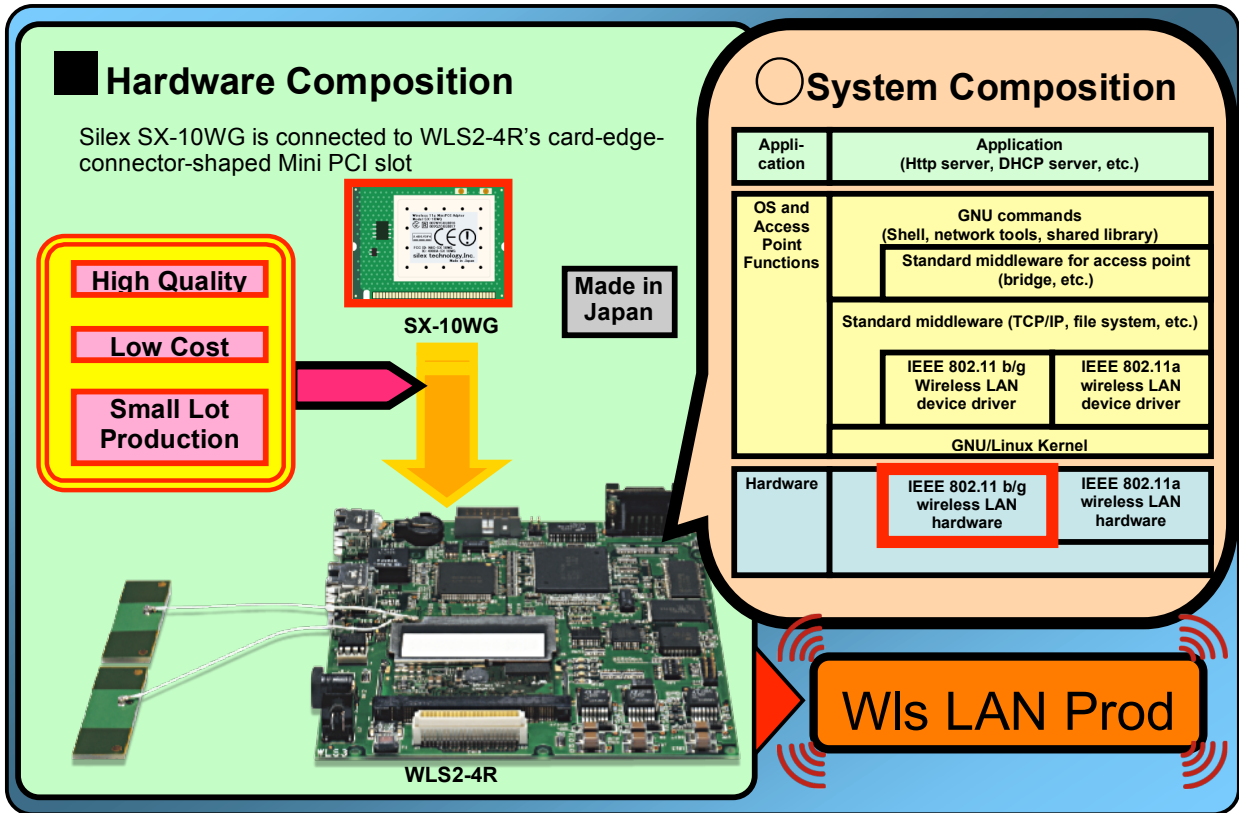

Hitachi WLS2-4R with Silex SX-10WG

Summary

When evaluating embedded wireless modules, you need to consider more than just price. Quality must be a primary factor in the decision process, because the costs associated with poor quality can easily exceed any savings in the price of the modules. In order to ensure the highest quality product, the embedded wireless module manufacturer must control all aspects of quality from the initial product design to manufacturing and supply. In addition, the manufacturer must have a strong corporate commitment to quality, plus the ability to support your development and your on-going manufacturing requirements.